

**CREATE YOUR OWN
MONSTER**
FRANKENSTEIN
Pleasanton, KS, U.S.A.
Made with Pride **TRIKES**

Installation Guide

Street

36" Light Sport Trike Kit

All Years



INCLUDED IN YOUR TRIKE KIT:

COMPONENTS

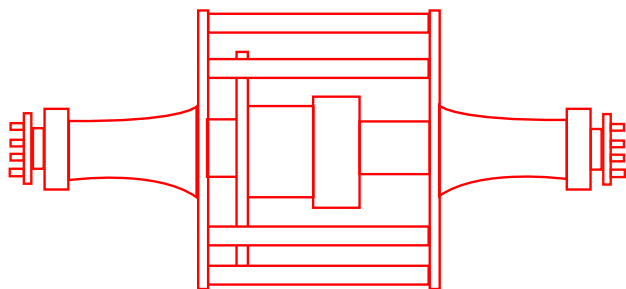

Frankenstein Trikes Rear End

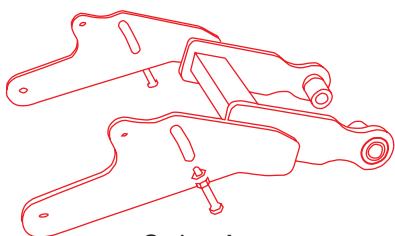

Swing Arm

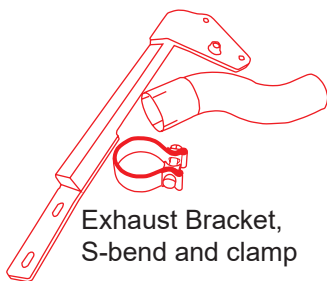

Exhaust Bracket,
S-bend and clamp



2 Fenders

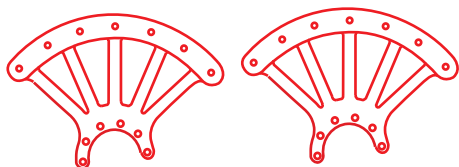

2 Fender Brackets

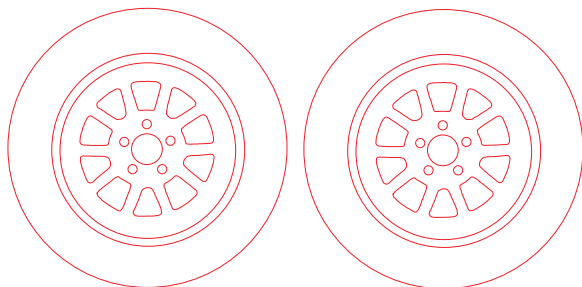

2 lon 15" X 8" wheels style 171-5865-MB

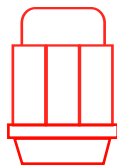

10 lug nuts

1

2 Center caps and 2 Hankook Ventus 205/50/15 tires

HARDWARE

PULLEY MOUNTING (all ready installed)

5 pcs. - 7/16" -14 x 1 1/2" Grd. 8 (Gold) Bolt

5 pcs. - 7/16" Lock Washer

FENDER MOUNTING

14 pcs. - 3/8" - 16 x 1" Grd. 5 (Zinc) Bolt

14 pcs. - 3/8" I.D. 1" O.D. 1/16" Thick Grd 5 Washer

12 pcs. - 3/8" -16 Nylock Nut

2 - 3/8" - 16 Thin Nylock Nut (Fender Strap)

NOTE! Additional hardware used to mount fender brackets to the rear end are pre-installed onto the rear end.

SHOCK MOUNTING

2 - 1/2" - 13 x 2 1/4" Grd. 8 Bolt (Lower Shock Mount)

2 - 1/2" I.D. 1 1/4" O.D. 1 1/2" Long Spacer (Upper Shock Mount)

2 - M12-1.75 x 120mm 10.9 Steel Bolt (Upper Shock Mount)

4 - 1/2" I.D. 1" O.D. 1/8" Thick Grd 8 Washer (Shock Mount)

EXHAUST BRACKET

1 - M8 - 1.25 x 40mm Bolt

WHEEL MOUNTING

10 - Lug Nuts



LOCTITE is included with every kit and must be used where instructed in this manual.

STAGE 1. Motorcycle Preparation:



Always refer to your Harley-Davidson owners manual before performing any work on your bike.

1. Secure front wheel so motorcycle won't tip, set jack under the motorcycle and raise the jack to take the weight off of the rear wheel.



Factory exhaust will be too long for your Frankenstein Trike Kit.

2. Remove muffler. If you have short exhaust you can leave them attached.

3. Remove rear wheel.

4. Remove shocks from both sides.



5. Unbolt the master cylinder and exhaust bracket from bike. Remove master cylinder from bracket. Save exhaust bracket for modification later.



TIP Do not disconnect brake line from caliper. Caliper will be bolted to new caliper bracket later in the installation.



6. Remove front pulley cover.



Note: The position of the spacer on the left outside of the swing arm. This spacer will be reused.

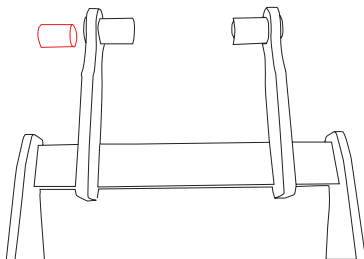

7. Remove swing arm pivot shaft
Remove swing arm & belt.
Save spacer you will need it for your new swing arm.

STAGE 2. Rear End Preparation/Installation:

1. With swing arm and rear wheel removed, have a friend help set a wheel and tire on the brake side of the rear end. Install with lug nuts.
2. Set the rear end on the wheel that was previously installed. Remove the five bolts to the spokes, Remove axle, axle housing and star plate as a unit.



Do not remove green tape, it will be used as a reference point in the following instructions.

TIP Install center cap into wheel before mounting.

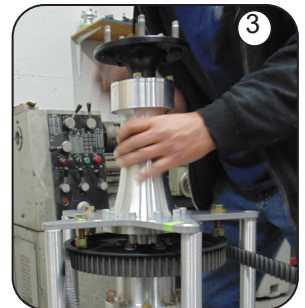
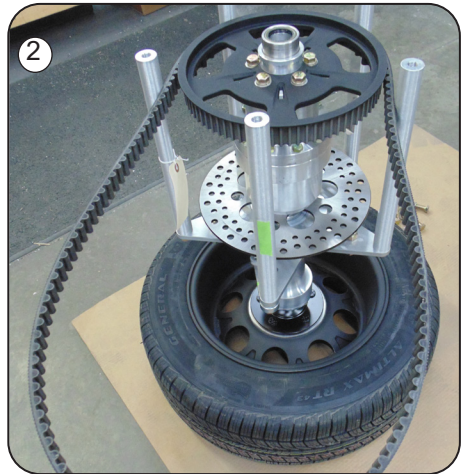

3. Install belt on pulley. Make sure that the belt goes around spoke with green tape on it as shown in picture 2. Reinstall star plate line up green tape on star plate with spoke. (see picture 3). Remove the 1/2" allens one at a time apply blue loctite and reinstall torque 60 ft. lbs. Both Sides. Have a friend help you place swing arm into place and insert correct bolt, finger tighten down to hold swing arm into place. Swing arm mounting bolts will be torqued later.



LOCTITE

5. When installing swing arm be sure to place the 1/4" thick washer between swing arm and star plate.(see pictures 5) Use blue loctite on swingarm mounting bolts. These bolts will be torqued after the belt has been adjusted. See diagram on page 8.

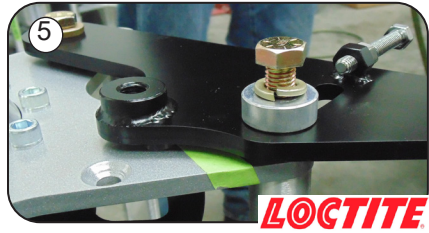
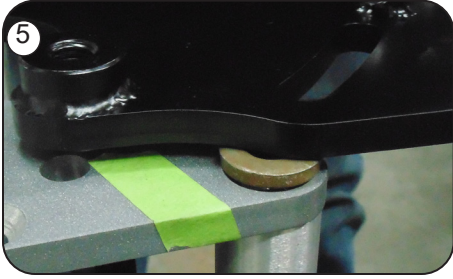

6. Carefully place the remaining tire onto the axle and tighten the lug nuts. Carefully lay the rear end down on both tires. Making sure the swing arm does not hit the ground. You will now be able to roll the rear end under your bike. Place belt around the front pulley lining up the teeth correctly. Insert pivot shaft through swing arm and torque pivot shaft. Adjust the bike to install the shocks.

7. Bolt the caliper to the caliper bracket installed on the rear end. Bolt the caliper and caliper bracket to the rear end with provided spacers

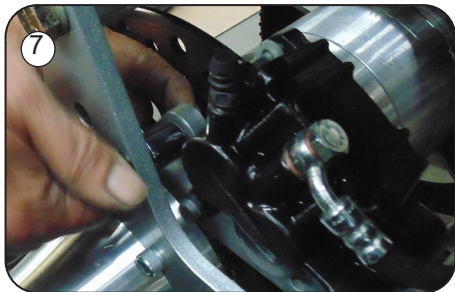
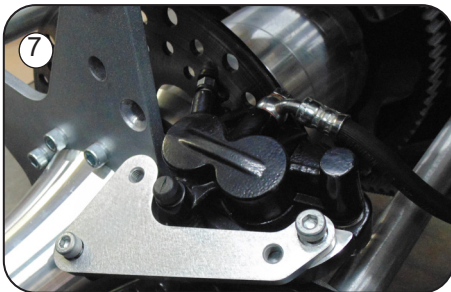

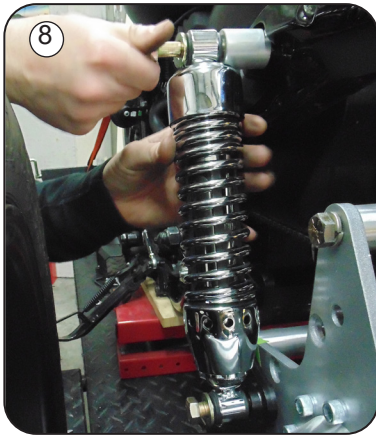

8. Install shocks and torque bolts.

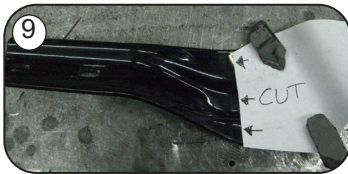
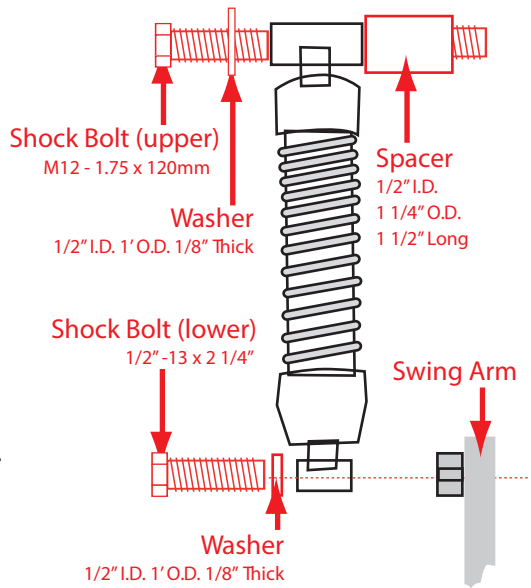

9. Using the template provided cut your exhaust bracket accordingly. Hold the template with magnets or clothes pins.

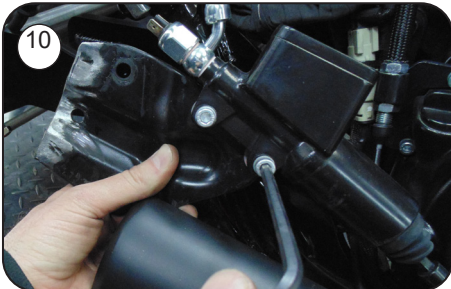

10. Attach master cylinder to modified exhaust bracket. Bolt old (modified) exhaust bracket to frame between new exhaust bracket and frame.

11. Install new exhaust s-bend (large end with cuts in it) on to the header pipe with stock exhaust clamp. Do not tighten clamp at this time. Install muffler on to new s-bend with new exhaust clamp. Do not tighten at this time. Bolt muffler to new exhaust bracket. You may have to twist the s-bend so the muffler will line up with the exhaust bracket mounting holes. Tighten up the muffler mounting bolts. Tighten up both exhaust clamps.



Shown with axle and wheel removed.

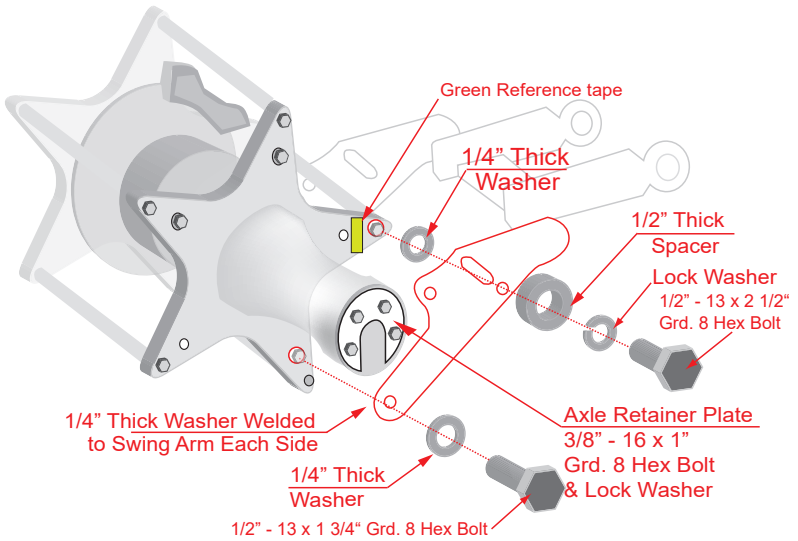
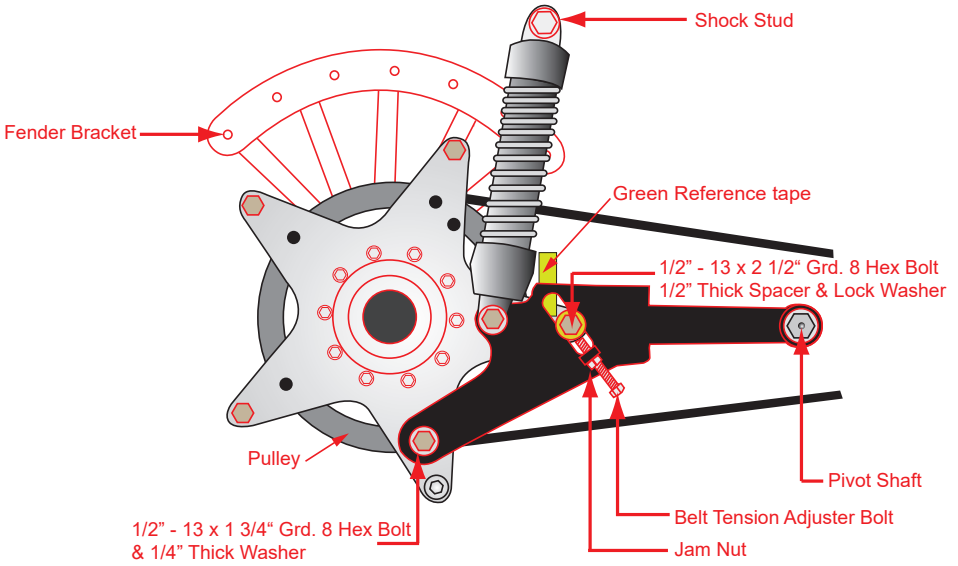

12. Attach fender brackets to fenders using supplied FENDER MOUNTING HARDWARE ★ *Note: side with more space from bolt holes to edge of fender goes toward the front.*

12

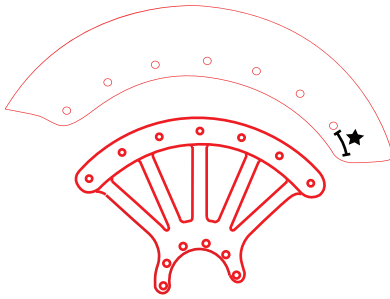

shown: left bracket and fender

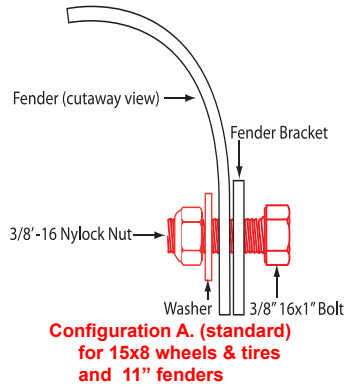

13. Install fender and bracket on the rear end with supplied hardware. Apply blue loctite. Torque fender bracket bolts to 45 ft. lbs. Repeat installation of fender and bracket for the other side of the trike.



14. Remove remaining star plate bolts one at a time apply blue loctite and hold adjustable wrench on flat area of spoke to torque bolts to 60 ft. Lbs.

⚠ **Do not torque front spoke at this time.**



 *The trike must be sitting on the ground on its suspension to adjust the belt.*

15. Adjust belt tension to factory specs.

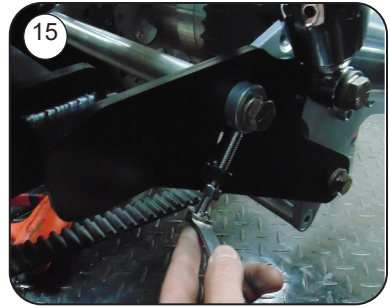

16. Tighten jam nut on adjuster bolts.

17. Torque the four rear end mounting bolts to 60 ft. lbs.

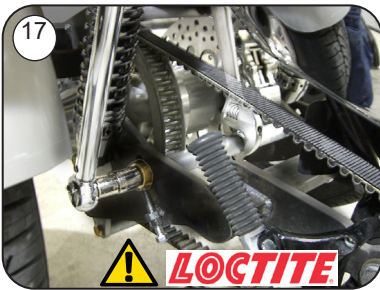

18. Hook up stock brake line, bled rear brake, tighten lug nuts on rear wheels torque 78 to 85 ft. lbs. and go for a ride. Re-torque lug nuts after 25 miles or 100 mile maximum.

**Tip: Recommended
tire pressure is 25psi.**

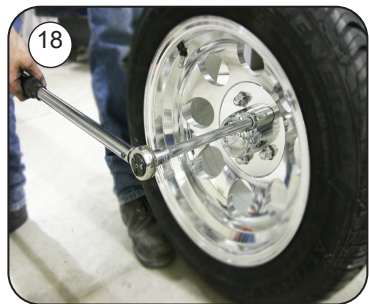

Note: Initially the brake and rotor need to be worn in before maximum braking can be achieved. Please use caution.

Our Trike rear ends are made from all 6061 T6 billet aluminum, except for our Light Sport Std. Trike rear end, which has 3/8" thick steel star plates, powder coated silver, instead of 1" thick billet aluminum star plates that we use on all our other Trike rear ends.

All of our rear ends have a Dana 30 differential, packed with Moly EP grease. 9" Ford street/strip axles with a bolt pattern of 5 studs on 4 1/2" bolt circle, wheel studs are 1/2" - 20. HHI/Frankenstein 4 piston billet caliper, 11 1/2" stainless steel brake rotor, or optional outboard Brakes with two HHI/Frankenstein 4 piston billet calipers and two 11" stainless steel brake rotors. We only use top quality new parts in our manufacturing of "Frankenstein Trikes" rear ends.

Replacement Parts

Differential seal: National oil seal # 481213 \$12.00 each

Differential Bearing: # 62102RS \$24.00 each

Axle Bearing: BCA # RW207-CCRA \$65.00 each

Brake Pads: HHI-101-001 \$39.00 pair

prices subject to change

